

## Replace pre-separation pad Replace separation roller

### Pre-separation Pad

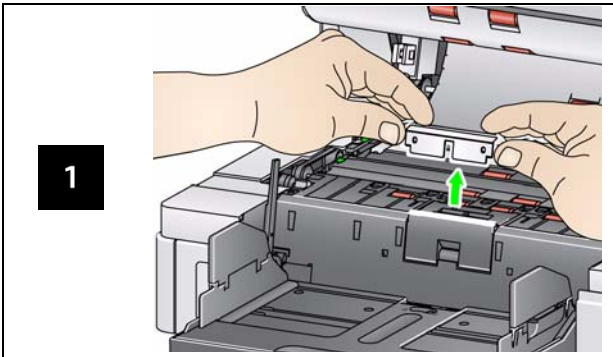

### Separation Roller

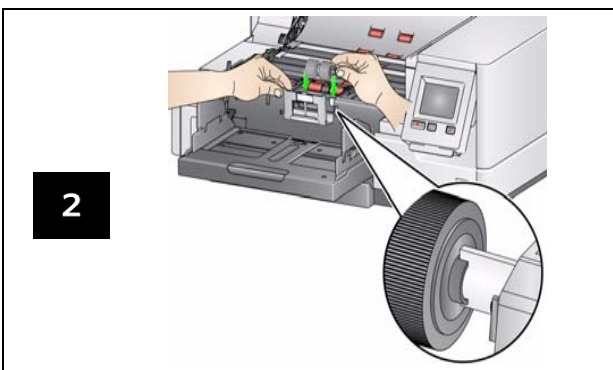
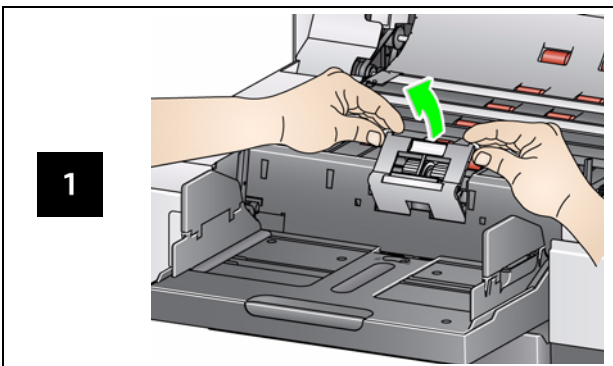

See the User's Guide for feed module replacement procedures.

## Supplies and Accessories

CAT No.	Description
832 7538	Feeder Consumables Kit
838 7938	Extra-Large Feeder Consumables Kit
146 2415	Extra-Extra-Large Feeder Consumables Kit
844 5280	Feeder Kit for Ultralightweight Paper
834 8054	Image Guide Set (without Printer)
871 4438	Image Guide Set (with Printer)
808 8239	Flippable Background (without Printer)
800 0853	Flippable Background (with Printer)
166 7641	i5850 Flippable Background (without Printer)
161 2605	i58050 Flippable Background (with Printer)
183 3946	66.04 cm (26 in.) document extender
162 6803	76.2 cm (30 in.) document extender
149 8476	86.36 cm (34 in.) document extender
167 3953	Manual Feed Shelf (i5200/i5600 Scanners)
169 4256	Manual Feed Shelf (i5800/i5850 Scanners)
150 9546	Controlled Dual Stacking Accessory
121 3743	i5850 Enhanced Printer Accessory (Front and Rear)
125 7633	Printer Ink Blotters
818 3386	Enhanced Printer Black Cartridge
159 6832	Enhanced Printer Red Cartridge
176 3218	Enhanced Printer: Ink Cartridge Carrier
896 5519	Staticide Wipes for Kodak Scanners
169 0783	Transport Cleaning Sheets
853 5981	Roller Cleaning Pads
826 6488	Brilliance Detailer Wipes

Contact your scanner supplier to order supplies.

Kodak Alaris Inc.  
2400 Mount Read Blvd.  
Rochester, NY 14615  
© 2014 Kodak Alaris Inc. All rights reserved  
A-61669 / Part #5K3171 June 2014

The Kodak trademark and trade dress are used under license from Eastman Kodak Company.



## i5000 Series Scanners



### Reference Guide

*The illustrations in this guide may look different than your scanner model. However, the procedures are the same, unless otherwise noted.*

## Support Information

[www.kodakalaris.com/go/disupport](http://www.kodakalaris.com/go/disupport)

**1.800.822.1414**

*(US&C only; all other regions, contact your local Kodak Alaris Support Center)*

When contacting support, have the following available:

- A description of your problem
- Scanner model and serial number
- Computer configuration
- Software application you are using

## Cleaning Frequency Chart

Procedure	Start of day	Middle of Shift	Start of new shift
1 Vacuum output tray and input areas (input elevator and transport)	x		
2 Clean all rollers; including feed module	x		x
3 Run transport cleaning sheet	x		x
4 Clean imaging guides	x	x	x

### IMPORTANT:

- ❑ The Roller Cleaning Pad contains sodium lauryl ether sulfate which can cause eye irritation. Refer to the MSDS for more information.
- ❑ Staticide Wipes contain isopropanol which can cause eye irritation and dry skin. Wash your hands with soap and water after performing maintenance procedures. Refer to the Material Safety Data Sheet (MSDS) for more information ([www.kodaklaris.com/go/MSDS](http://www.kodaklaris.com/go/MSDS)).

## Cleaning the transport and rollers

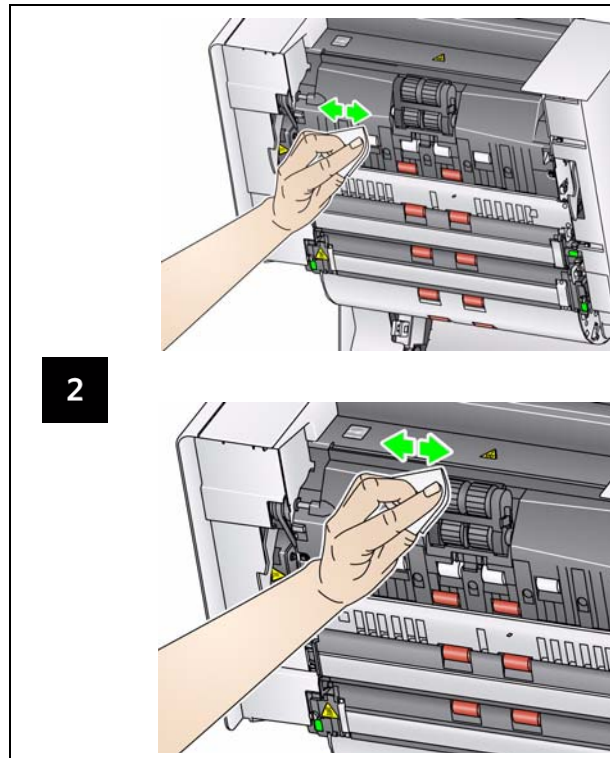
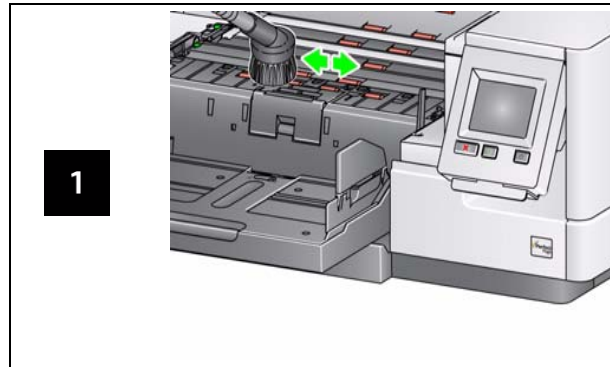

## Running a cleaning sheet and cleaning the imaging guides

